



Certificado de Conformidad

CERTIFICATE OF CONFORMITY

La empresa SOFAMEL S.L certifica que el producto descrito a continuación
The company SOFAMEL S.L certifies that the product described below

PRODUCTO PRODUCT

MANGUITO DIN 46267 DE COBRE TUBULAR Mod. MCD DIN 46267 COPPER BUTT CONNECTOR Mod. MCD

Características del producto Product characteristics

Los manguitos MCD están fabricados en cobre electrolítico con un acabado superficial estañado para mejorar el contacto eléctrico. Según DIN 46267.

MCD butt-connector manufactured from electrolytic copper with a tinned finish to improve electrical contact. According to DIN 46267.

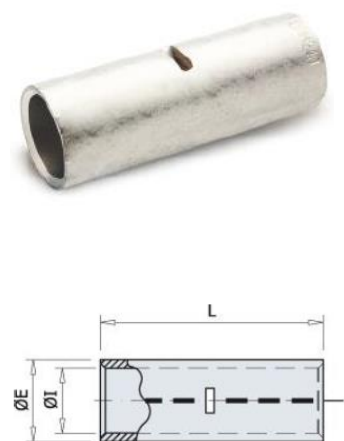

RANGO / DIMENSIONES DEL PRODUCTO									
Código	Ref.	Sección (mm ²)	Dimensiones (mm)			L	x 100	Bolsos	Caja
			ØE	ØI					
004130	MCD-6	6	5,5	3,8	30	0,340	100	800	
004140	MCD-10	10	6,0	4,5	30	0,340	100	500	
004150	MCD-16	16	8,5	5,5	50	1,514	100	200	
004160	MCD-25	25	10,0	7,0	50	1,844	50	150	
004170	MCD-35	35	12,5	8,2	50	3,214	20	120	
004190	MCD-50	50	14,5	10,0	56	4,450	20	90	
004200	MCD-70	70	16,5	11,5	56	5,655	20	60	
004210	MCD-95	95	19,0	13,5	70	9,023	10	40	
004220	MCD-120	120	21,0	15,5	70	10,135	10	40	
004230	MCD-150	150	23,5	17,0	80	15,181	10	30	
004240	MCD-185	185	25,5	19,0	85	17,726	5	25	
004250	MCD-240	240	29,0	21,5	90	24,576	5	15	
004260	MCD-300	300	32,0	24,5	100	30,550	5	10	
004270	MCD-400	400	38,5	27,5	150	78,517	2	6	
004280	MCD-500	500	42,0	31,0	160	92,638	1	5	
004290	MCD-625	625	44,0	34,5	160	86,026	1	3	
004300	MCD-800	800	52,0	40,0	200	159,197	1	5	
004310	MCD-1000	1000	58,0	44,0	200	205,918	1	4	

Cumple con los requerimientos establecidos por la Norma Is in accordance with requirements established by the Standard Norma de referencia / Reference Standard

Fabricadas siguiendo los criterios establecidos para cumplir con la Norma DIN 46267 Manguitos de cobre, para compresión, estañados, para conductores de cobre.

Manufactured according to the criteria established to comply with DIN 46267 copper butt-connector, for compressions, cover plated type, for copper conductors.

Febrero de 2019
February 2019

Firma / Signature:

Joan Margets Gumà
Director General / General Manager

Firma / Signature:

Sandra Pérez García
Resp. Calidad / quality Manager

El Sistema de Gestión de Calidad implantado en SOFAMEL cumple con la norma INTERNACIONAL ISO 9001:2015 y certificado por el organismo AENOR, acreditado por la entidad ENAC.
The Quality Management System established in SOFAMEL is based on the International Standard Norm ISO 9001:2015, and it has been certificated by the body AENOR, ENAC accredited body.